

ACCUBATH®

RECIRCULATING PROCESS VESSELS

the ultimate process vessels



SUPERIOR PARTICULATE CONTROL FOR IMPROVED YIELD

IMTEC's ACCUBATH line of constant temperature recirculating vessels evolved from user demand for systems with improved particulate removal capability.

Our recirculating vessels are a family of reliable and precise production tools. When integrated into a recirculating system, they provide optimum process control without compromising reliability or safety.

IMTEC'S PATENTED DESIGNS

At the leading edge of recirculating bath technology, IMTEC's patented QRT/S models feature a 360° weir and raised trough feeding an unheated sump.

Other recirculating baths have an integral trough allowing high temperature chemical to overflow onto the flange causing premature failure of the RTV Seal. The IMTEC QRT/S vessels have a trough that is separated from the flange to prevent this condition.

OPTIMIZED FLOW FOR IMPROVED PROCESS PERFORMANCE

The vessel is provided with sparger inlets and an (optional) quartz fluid-dispersion plate to direct the filtered solution into an optimal flow pattern for particle removal from the wafer surface and carry off over the weir edge. To further enhance the weir sweep action, IMTEC supplies 45° chamfered knife edge scalloped pattern at the weir parameter, creating a series of flow plumes that pull particulate up and over the weir, even if flow rates are marginal. The housing is sealed to the quartz chamber with a sealant selected for specific resistance to either organic solvents (gray) or acids (white). The sump separates entrapped vapor and air prior to pump entry (a critical condition for bellows pump operation) and increases process safety by maintaining bath working chamber liquid level regardless of large fluctuations in total liquid capacity. Within wide limits, variations in working chemistry volumes result only in liquid level changes within the unheated sump; thus, bath flow characteristics are not affected and heater elements remain covered.

FLEXIBLE CONFIGURATION

Accubath recirculating vessels are available in standard sizes from 100mm to 800mm substrates. Custom sizes are also available to accommodate virtually any special requirement.

ACCOMMODATES A RANGE OF PROCESSES

IMTEC's QRT/S is engineered to accommodate chemical flow rates of up to 50 liters per minute and liquid levels changes associated with wafer cassette immersion and removal. Generous sump capacity allows maximum period between replenishment of acid due to drag-out and light-fraction evaporation losses.

IMTEC®

Corporate Offices: 1295 Forgewood Avenue • Sunnyvale, CA 94089 USA Phone: (408) 745-7800 • Fax: (408) 734-4883
e-mail: sales@imtecacculine.com • www.imtecacculine.com

NITRIDE ETCH AND SOLVENT VESSELS

The basic vessel can be equipped with the IMTEC quartz Cooling Collar and Autolid to provide high cleanliness phosphoric etch systems or low-evaporation solvent systems. IMTEC QRT/S vessels can operate up to 190°C.

STANDARD FEATURES

- Ultra pure molded or plate quartz
- Proprietary high-resistant acid seals
- Inconel stainless steel heater system bonded to the quartz vessel wall for optimum heat transfer and ling life
- Leak Detection Strips on every tank
- Engineered T-Bar structure to support and isolate the process vessel from case thermal stress
- Integrated internal Snap Switch and T/C's
- Quartz drain stems extending out of the bath case for high internal leak integrity
- Heat isolated quartz flange seal system for maximum bath life
- Packed alumina-silicate fiber insulation eliminating flame space
- Operation up to 190°C

OPTIONS

- Platinum wire Resistance Temperature Detector (RTD)
- Dispersion plates – gas & liquid
- Hinged or removable manual or auto lids
- Proprietary acid regeneration or overflow tube
- Solvent (including NMP) seal
- FM-4910 Approved Housing and flanges
- AQUASEAL – which extends the warranty to 30 months
- Standard and Nitride dedicated controllers available
- Leak Detection Modules

Specifications

QRT/S

A1002-11
A1252-14
B1501 -13
D1501 -10
A1502-18
A2001-25/12
A2001-25/11
B2001-34
A2002-51

Nominal Liquid Capacity

(liters)

11
14
13
10
18
25
25
34
51

Capacity

(wafer boats)

1 ea.100mm
2 ea.125mm
1 ea.150mm
1 ea.150mm
2 ea.150mm
1 ea. 200mm
1 ea. 200mm 1
1 ea. 200mm or 2 ea.150mm
2 ea. 200mm

Inside Process Vessel

Length Width Depth

11.5*	7.5	7.5
13.5	7.5	8.5
9.9	8.6 1	0.8
9.8	8.6	9.5
16.0	8.0	9.6
11.0	12.0	11.5
2.0	11.0	11.5
16.0	10.5	12.0
21.5	11.5	12.5

QRT/S

A1002-11
A1252-14
B1501 -13
D1501-10
A1502-18
A2001-25/12
A2001-25/11
B2001-34
A2002-51

Req'D Mounting Cut-Out

Length (A) Width (B) Depth (C)

19.7*	11.1	11.1
21.3	11.1	12.1
17.5	12.0	13.5
16.7	12.3	12.1
23.6	11.4	12.1
19.6	15.4	14.0
21.1	14.4	14.0
23.6	13.9	14.4
29.9	14.9	15.1

Required Deck Area

Length (D) Width (E) Height (F)

21.3	11.9	3.8
20.6	11.9	3.9
18.4	13.0	3.8
18.4	13.0	3.8
24.6	12.4	4.1
20.8	12.0	4.0
22.3	15.6	4.0
24.8	15.1	4.1
31.2	16.2	4.0

Power Wattage

(at 208V)

2100
2800
2030
1770
4000
4330
4330
5878
7100

Sink cut-out is measured from below tank flange. Deck area is measured from above tank flange. Custom sizes available; fabricated from plate or molded quartz.

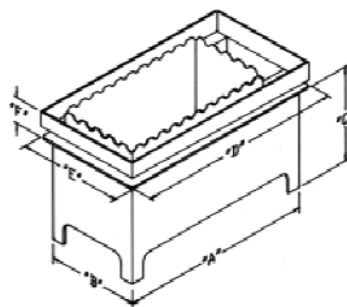

For over 30 years IMTEC has consistently produced high-quality, innovative products to give our customers the most value for their investment.

IMTEC – we make the difference in performance

12 MONTH WARRANTY

ACCUBATH® products carry the IMTEC 12 month warranty. As with all IMTEC products, the ACCUBATH® product line benefits from over 30 years of experience and innovation that have Made IMTEC the industry leader in process vessels for the semiconductor industry. IMTEC products are UL recognized and CE Certified. IMTEC Acculine, LLC is ISO 9001:2000 registered.